

# **Tisch Environmental, Inc.**

## **OPERATIONS MANUAL**

### **TE-2000P High Volume Air Sampler**



145 South Miami Avenue  
Village of Cleves, Ohio 45002  
Toll Free: TSP AND - PM10  
(877) 263 - 7610  
Direct: (513) 467-9000  
FAX: (513) 467-9009  
Web Site: [www.Tisch-Env.com](http://www.Tisch-Env.com)  
Email: [sales@tisch-env.com](mailto:sales@tisch-env.com)

## Model TE-2000P HANDI-VOL

- Determines in-plant pollution levels
- Spot checks suspected sources of pollution
- Verifies industrial hygiene standards
- Checks compliance measurements in isolated areas
- Compact "sample anywhere" design
- Lightweight, heavy duty industrial construction

The Handi-Vol TE-2000P is especially suited for intermittent verification and determination of airborne particulate levels. Utilizing a 4" diameter filter paper of various types, the unit traps particles to .01 microns.

The peripheral by-pass design of the blower motor allows independent discharge of the sampled air. Motor cooling is provided by a separate fan section. This feature provides longer sampling periods without motor burnout.

The "swing away" bolts on the filter holder facilitate paper replacement and eliminate damage to the filter media while clamping.

The sampler unit is assembled ready for operation with filter holder, flowmeter, integral handle, rubber tipped feet and polarized electrical cord, and off-on switch.

### **SPECIFICATIONS:**

MOTOR HP.....	7/8 hp
FLOW RATE ..... (with 4" filter holder) .....	15 CFM to 25CFM
SPEED .....	13,000 rpm
NET WEIGHT.....	22 lbs.
AMPERAGE .....	9.5
FLOW RATE ..... (with 8x10" filter holder) .....	20 CFM to 60 CFM
WATTAGE .....	1095
OVERALL DIMENSIONS .....	14"L x 14"H x 10"
POWER SOURCE .....	115v, 1Phase, 60hz

## TE-2000P AIR SAMPLER CALIBRATION & SAMPLING PROCEDURES

Equipment needed to conduct calibration of the TE-2000P Air Sampler:

- . TE-2000P Air Sampler
- . Model TE-5026 Calibration Orifice
- . Three Calibrating Plates (3, 2, and 1.5)
- . Two Rubber Gaskets
- . One U-Tube Manometer
- . Tygon Tubing
- . Flow Meter Calibration Chart Paper
- . GF/C, 10/11 cm Filter (Glass Fiber Filer)
- . 5/16" Wrench
- . Nail Polish
- . Nail Polish Remover

### CALIBRATION PROCEDURE

Step 1: Remove the 10/11 cm filter holder from the inlet of the air sampler.

Step 2: Plug the air sampler into correct voltage source.

Step 3: Install the #3 calibration plate in the calibration orifice and attach to the sampling pump (a gasket goes on each side of calibration plate).

Step 4: Turn the unit on and allow the pump to warm-up for approximately five minutes.

Step 5: Open both fittings on top of the U-Tube manometer.

Step 6: Zero the manometer.

Step 7: Attach one end of the tygon tubing to the pressure tap on the calibrating orifice and the other end to either fitting post of the U-Tube manometer.

Step 8: With the #3 calibration plate in place and the sampler running, adjust the float, if necessary, to "8" on the flowmeter.

Step 9: Observe the "inches of water" on the U-Tube manometer. Read at eye level and add both sides of manometer.

Step 10: Record the "float" reading and the U-Tube reading on the bottom of the Flowmeter

Calibration Chart paper. (Attachment 3)

Step 11: Turn the unit off, insert the #2 Calibration plate, turn unit on, observe the "inches of water" on the U-Tube manometer (Read at eye level and add both sides of manometer).

Step 12: Record the "float" reading and the U-Tube reading on the bottom of the Flowmeter Calibration Chart paper. (Attachment 3)

Step 13: Turn unit off, insert #1.5 Calibration plate, turn unit on, observe the "inches of water" on the U-Tube manometer (Read at eye level and add both sides of manometer).

Step 14: Record the "float" reading and the U-Tube reading on the bottom of the Flowmeter Calibration Chart paper. (Attachment 3)

Step 15: Turn unit off.

Step 16: Remove the tygon tubing from the calibration orifice and the U-Tube manometer. Close both top ports on the manometer.

Step 17: Remove the calibration orifice from the pump.

Step 18: Put manometer and orifice into calibration case.

## PLOTTING THE CALIBRATION CURVE

Step 1: From the data recorded at the bottom of the Flowmeter Calibration Chart and using the "Air Sampler Calibration Curve", develop a calibration curve for the air sampler. (See example, Attachment 3)

- For each number in the "inches of water" column move vertically (y-axis) the required number of spaces (each space = 0.1).
- When reaching the required number of spaces (y-axis) move horizontally (x-axis) until this line intersects with curve.
- Drop vertically to the x-axis to find the Actual Flow Rate.
- Record this number in the "Actual Flow Rate" column on the Flowmeter Calibration Chart.

Step 2: Repeat this procedure for each plate reading.

Step 3: Using the "Flowmeter Reading" and "Actual Flow" numbers obtained in Steps 1 & 2, develop calibration curve for the pump.

- Using Flowmeter Reading number, proceed horizontally along x-axis until reaching desired number.
- Proceed vertically up the y-axis until reaching number in Actual Flow column.
- Place a mark where these two numbers intersect.
- Repeat this procedure for each set of data points.

Step 4: Using a protractor, straight edge, or flexible rule connect the three marks on the chart with a continuous line. THIS IS THE FLOWMETER CALIBRATION CURVE FOR THE AIR SAMPLER.

Step 5: On the Flowmeter Calibration Chart record the air sampler pump #, calibrator #, and date of calibration.

### DETERMINING AIR SAMPLING FLOW RATE (CFM)

Step 1: Place a clean unused GF/C 10/11 cm filter in the air sampler filter holder, tighten making sure of no leaks.

Step 2: Turn air sampler on and read the flow meter gauge.

Step 3: Turn unit off.

Step 4: Using the flowmeter gauge reading, move horizontally along the x-axis to the number on the chart the corresponds to the number on the gauge.

Step 5: Move vertically (y-axis) until the line intersects with the curve.

Step 6: Move horizontally to the left (y-axis) to obtain the Cubic Feet per Minute (CFM) reading for the air sampler. This number (CFM) is to be used until the next calibration date.

Step 7: Record this number on the Flowmeter Calibration Chart.

Step 8: Place this record and all other calibration records in a notebook .

# Model Handi-Vol TE-2000P

## Replacement Parts and Accessories

1) Replacement motor only .....	TE-10296
2) Replacement Brush Set, 4pc.....	TE-
10542	
3) Aluminum Housing.....	TE-10351
4) Aluminum Cap Ring .....	TE-10352
5) Aluminum Base Mounting Bracket.....	TE-10445
6) Housing Seal Gasket, neoprene .....	TE-10447
7) Cap Ring Compression Gasket, neoprene.....	TE-10448
8) Housing Bolts, 1/4-20 x 6-1/2" .....	TE-10449
9) Power Cord Set 8ft .....	TE-4014
10) Flowmeter . . . . .	TE-10453
11) Replacement Fuse, 15 amp.....	TE-10458
12) Aluminum Handle Bracket.....	TE-10459
13) Motor Cushion, 4"ID x 7"OD Silicone .....	TE-10540
14) Filter Holder, 4" round.....	TE-1008
15) Teflon Gasket, Top . . . . .	TE-1008-5
16) Teflon Gasket, Bottom . . . . .	TE-1008-5
17) Calibration Kit Complete.....	TE-5026
18) Tri-pod Stand for G2000P .....	TE-2000PS
.....	

Attachment 3  
 Typical 2000-P Flowmeter  
 calibration curve  
 Note: For information only.

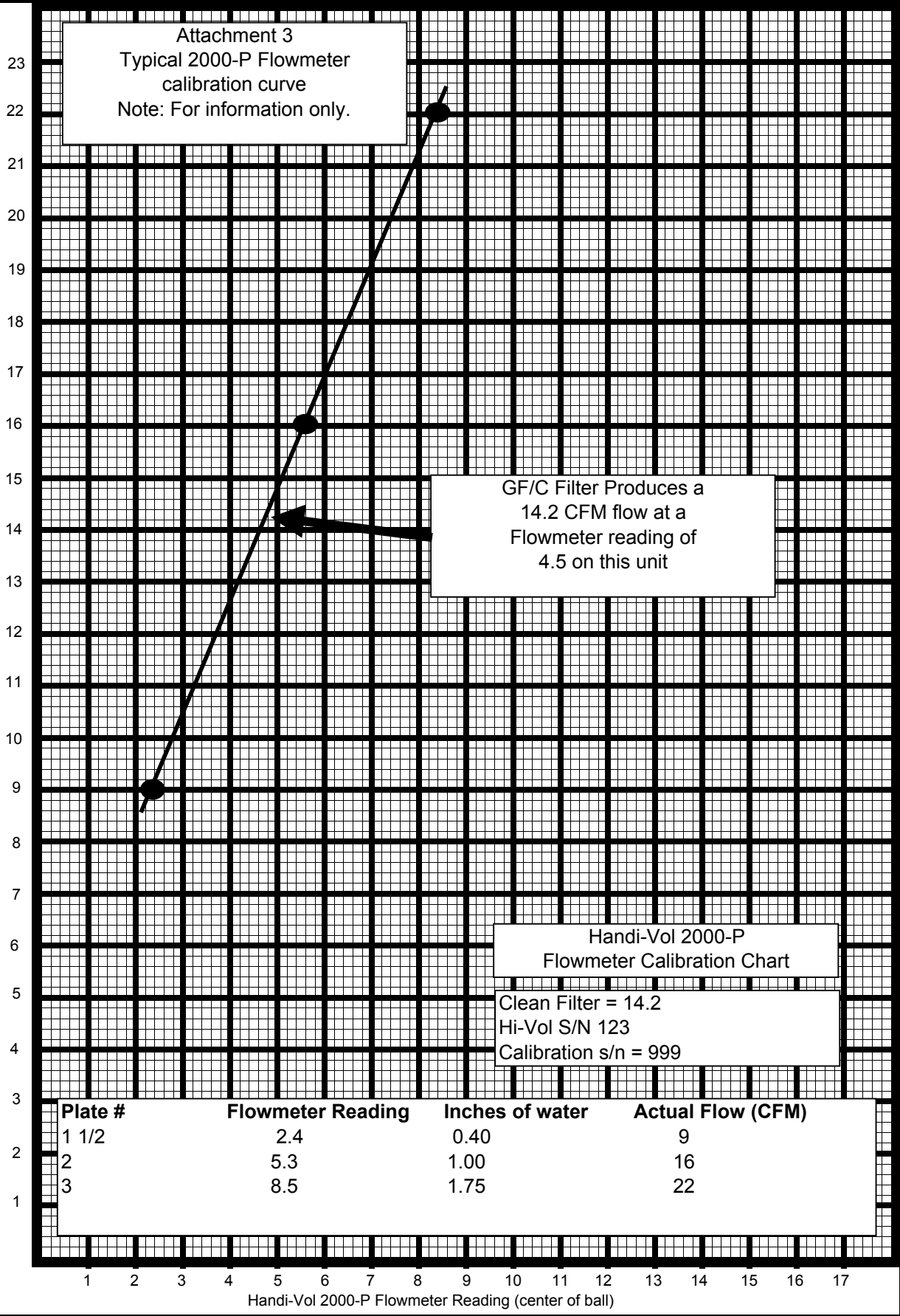

GF/C Filter Produces a  
 14.2 CFM flow at a  
 Flowmeter reading of  
 4.5 on this unit

Handi-Vol 2000-P  
 Flowmeter Calibration Chart

Clean Filter = 14.2  
 Hi-Vol S/N 123  
 Calibration s/n = 999

Plate #	Flowmeter Reading	Inches of water	Actual Flow (CFM)
1 1/2	2.4	0.40	9
2	5.3	1.00	16
3	8.5	1.75	22

Handi-Vol 2000-P Flowmeter Reading (center of ball)

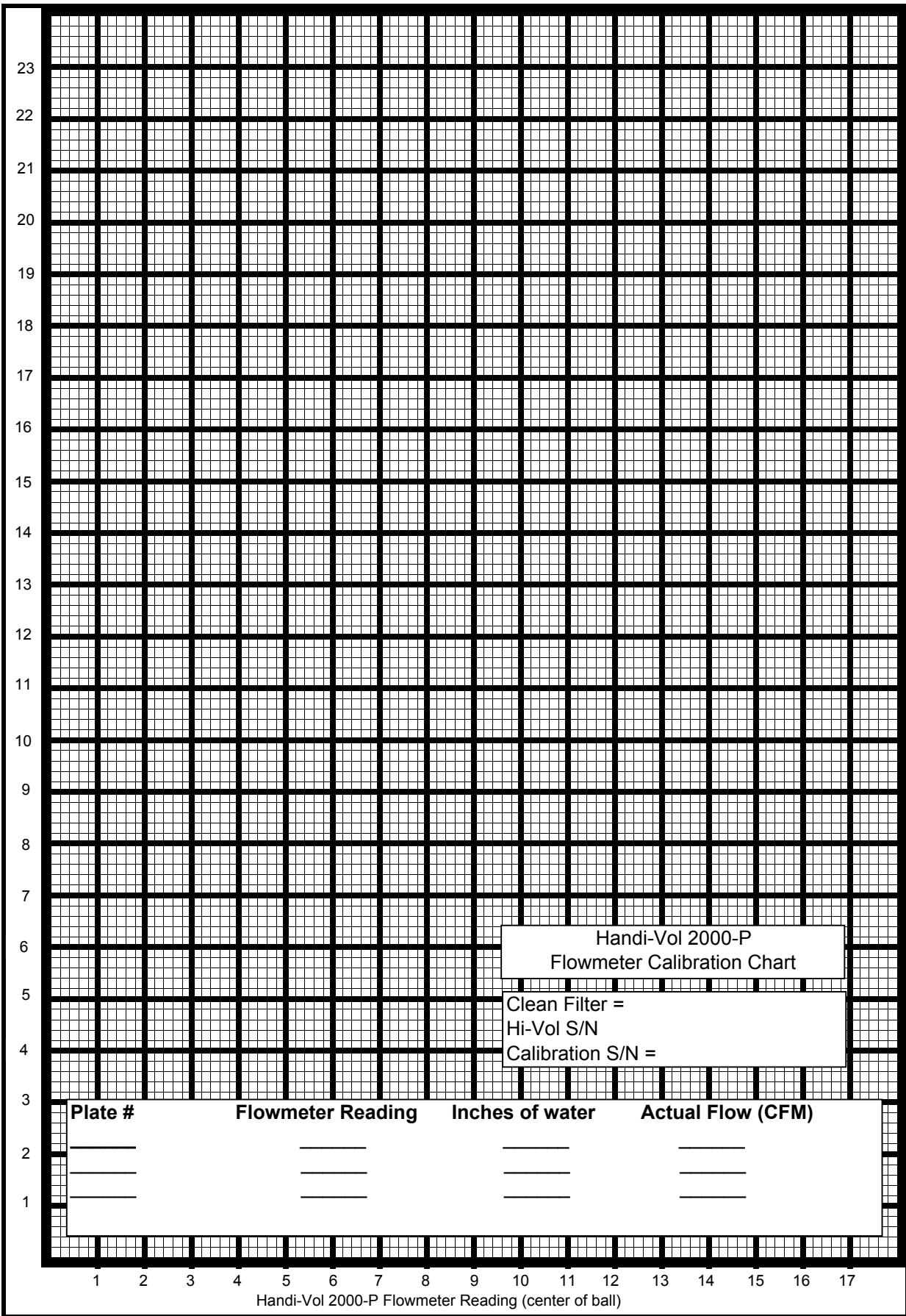

**"Inches Water Manometer"  
 Calibrator Orifice Static Pressure  
 $\Delta H$  inches of  $H_2O$  (6)**

**GMW-2000-P Pump Calibration Curve "Attachment 2"**

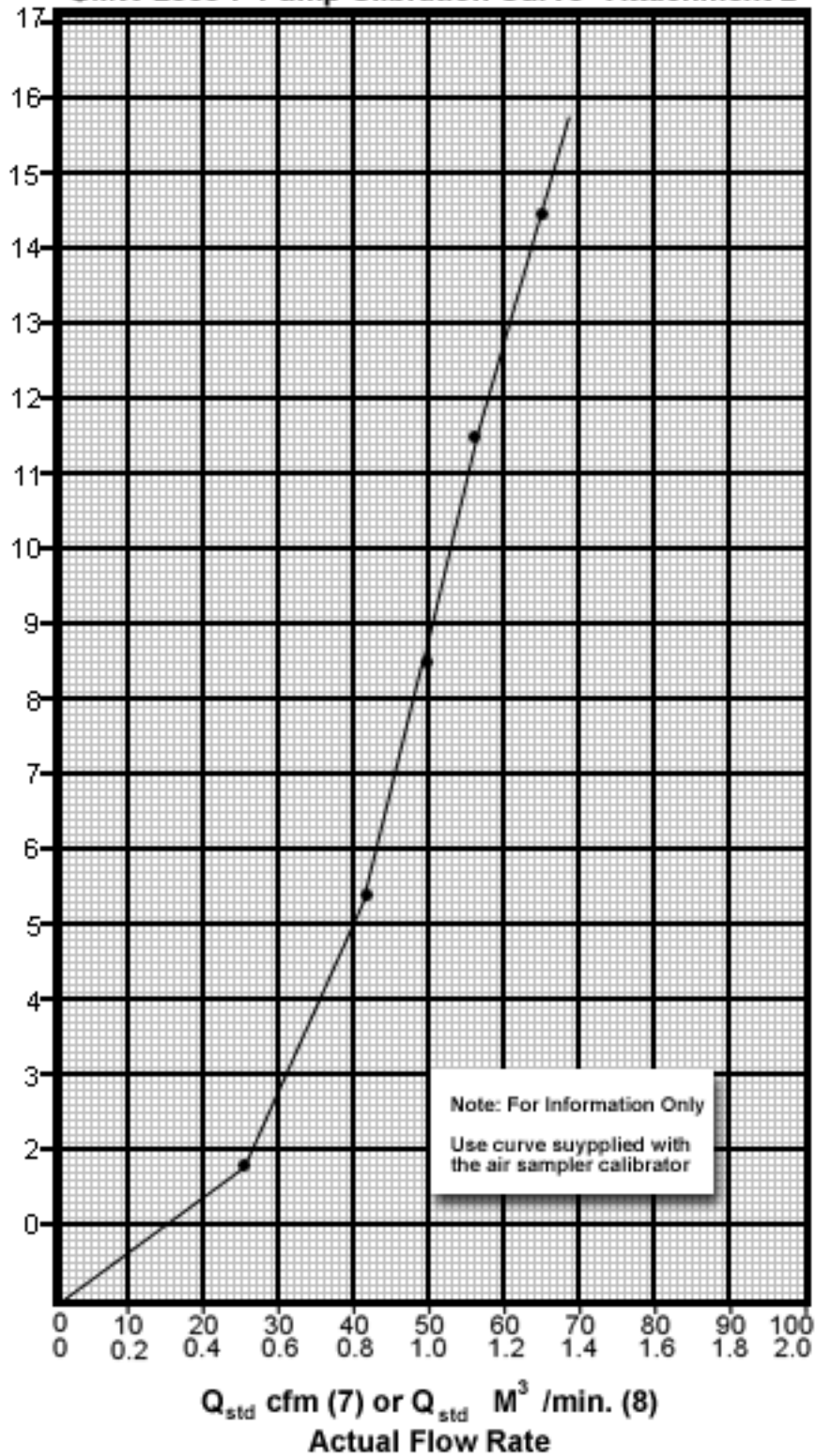

This plot is in (check one)

cfm \_\_\_\_\_

$M^3/m.$  \_\_\_\_\_

They are not equivalent

## BRUSH AND ARMATURE CHANGE

Tools needed to change brushes and armature of the TE-2000P High-Volume Air Sampler:

- . 5/16" Nut Driver
- . 1/4" Nut Driver
- . 9/16" open end wrench
- . 6" flat blade screwdriver
- . set of allen wrenches

(\*\*\* Caution: Remove power from unit before servicing. \*\*\*)

1. Remove 4" filter holder (TE-1008) and turn unit sideways. With a 5/16" nut driver, remove the four acorn nuts (TE-10779) from the Brush Holder Caps (TE-10778).
2. Remove the Brush Holder Caps and set aside. This exposes the four Brush Assembly Clips (TE-5172).
3. Remove the four Brush Holder Cap studs with a 1/4" nut driver. Each brush mechanism will fall out attached only by the field wire. Inspect the commutator for excessive wear or burned spots. If the commutator is okay, proceed with the brush change. If not, replace armature.
4. Remove the copper Brush Assembly Clips to release the brush and spring assemblies (TE-10542).
5. Remove the two Brush Mechanisms (TE-33300). Release the field wire from each brush mechanism. Set aside the brush mechanisms.
6. Remove the two screws on the Cord Connection Box (TE-10692). Lift and rotate to expose the internal wires.
7. Remove the three wire nut connectors that are connected to the motor. Gently pull the motor wires out of the cord connection box. Set the cord connection box aside. Pull to remove the black sleeving from the motor wires and set aside.
8. Turn the unit upside down. Insert the correct allen wrench into the armature shaft. While holding the allen wrench firmly, use a 9/16" open end wrench to remove the armature hex nut and washer.
9. Turn the unit over again. Using a flat blade screw driver, remove the two long field

screws (30-7934).

10. Lift off the Commutator End Bracket (TE-10667) and inspect the bearing sleeve for excessive wear (If worn,replace). Set aside. This exposes the armature commutator, cooling fan, and bearing assembly.

11. Lift the armature up and out of the motor. Remove the field winding (TE-10553) set aside.

12. The bearing in the Fan End Bracket (TE-10747) must be removed. From the other end of the motor, carefully insert a long screw driver to tap out this spent bearing. Stick the long screw driver down through the middle of the motor to align the internal fans and parts.

13. Set the field winding back onto the motor. Make sure the field wires are pointing in the original direction toward the cord connection box.

14. Remove nut from new Armature and install the new armature with new bearings down through the field winding. Do not force but wiggle lightly to align the internal fans and parts.

15. Replace and tighten the commutator end bracket with the two long field screws.

16. Insert new carbon brushes in the brush holders and secure with the four brush assembly clips.

17. Attach field wire to each brush mechanism.

18. Secure Brush mechanisms with the four Brush Holder cap studs. Attach the two Brush Holder Caps with the four acorn nuts.

19. Turn the unit over to re-install the washer and nut (Caution: The rounded edge side of the washer must be placed against the fan). Tighten securely.

20. Turn the unit back over and replace the black sleeving on the field wires.

21. Insert the field wires back into the cord connection box and wire-nut to the power cord, switch and fuse holder ( Caution: make sure green wire gets wire nutted to the other green wire, the black wires are interchangeable).

22. Attach the cord connection box to the motor bracket.

23. Turn unit up-right and re-install 4" Filter Holder.

24. To break in the new armature and brushes, run the motor for 1/2 hour at approximately 50% voltage using a TE-5075 Brush Miser or variac.

25. The Brush and Armature change is now complete.

ATTACHMENT 1

2000-P

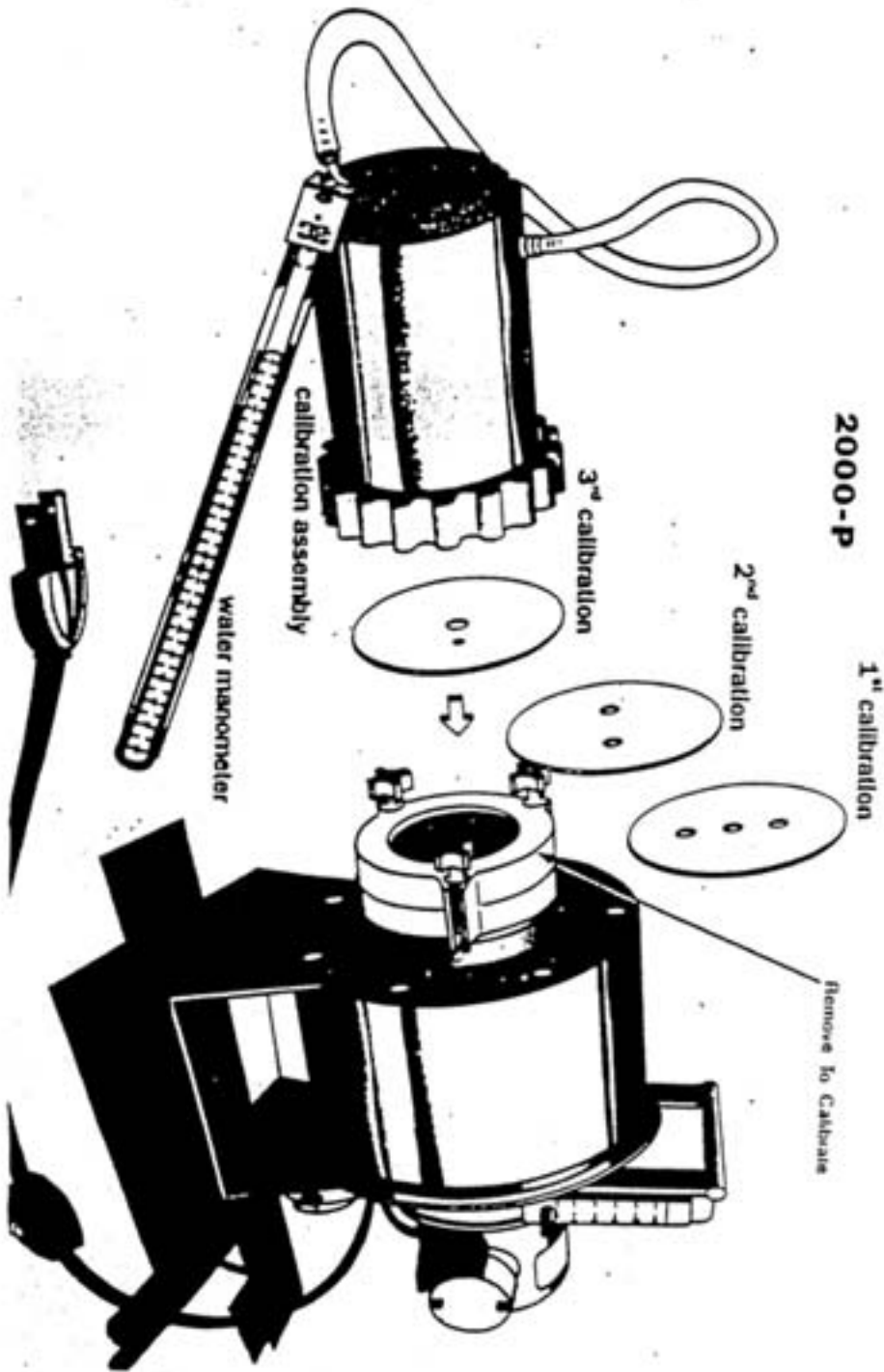

- |      |             |  |
|------|-------------|--|
|      | TE-2000P-1  | Tri-Pod Stand (Only)   |
| (1)  | TE-2000P-14 | Aluminum CAP Ring and Handle with pressure tap   |
| (2)  | TE-2000P-15 | Outer Cap ring gasket (9 1/2")   |
| (3)  | TE-2000P-16 | Inner Cap ring gasket (7 1/4")   |
| (4)  | TE-114787   | Motor for 110v TE-2000P Industrial Hygiene Sampler   |
|      | TE-114789   | Motor for 220v TE-2000P Industrial Hygiene Sampler   |
| (5)  | TE-2000P-17 | Motor Cushion Silicone   |
| (6)  | TE-2000P-18 | Aluminum Housing   |
| (7)  | TE-5035-2   | Male Adaptor Thread  |
| (8)  | TE-1008-8   | Filter Holder Gasket (Silicone 4 1/4" OD)  |
| (9)  | TE-1002-14  | Plastic Thumbnut, Washer, Brass Bolt and S/S Bolt each<br>(3 required)   |
| (10) | TE-1008-2   | 4" Filter Holder Body w/ S/S Screens   |
| (11) | TE-1008-5   | Teflon Gasket each (2 required)  |
| (12) | TE-1008-1   | 4" Hold Down Frame   |
| (13) | TE-1008-9   | Aluminum Cover for 4" Filter Holder  |
| (14) | TE-2000P-19 | Power Cord (6ft. long)   |
| (15) | TE-2000P-20 | Fuse Holder  |
|      | TE-2000P-21 | Fuse (15 AMP) Not Pictured   |
| (16) | TE-2000P-22 | Switch (on-off)  |
| (17) | TE-5012-6   | Elapsed time indicator 110v 60Hz Resettable  |
|      | TE-5010-6X  | Elapsed time indicator 220v 50Hz non Resettable  |
| (18) | TE-10453    | Flow Meter   |
| (19) | TE-5005-6   | Tubing 3 ft. Long  |
| (20) | TE-2000P-3  | Brushes Set (4 per set) for 110v   |
|      | TE-2000P-8  | Brushes Set (4 per set) for 220v   |
|      | TE-2000P-4  | Armature Kit for 110v Motor TE-114787  |
|      | TE-2000P-9  | Armature Kit for 220v Motor TE-114789  |
|      | TE-2000P-13 | GF/C Filters 10cm (100 per box)  |
|      | TE-2000P-5  | GF/C Filters Polybag 10cm (100 per box)  |
|      | TE-1008     | 4" round (10-11cm) filter holder complete  |
|      | TE-2000P-10 | Vinyl Cover to protect TE-2000P when not in use  |
|      | TE-5026     | Calibration kit with calibration orifice, monometer, three<br>load plates, tubing, NIST calibration certificate, carrying<br>case complete kit |

